

# Specialized Environmental Sensor Case

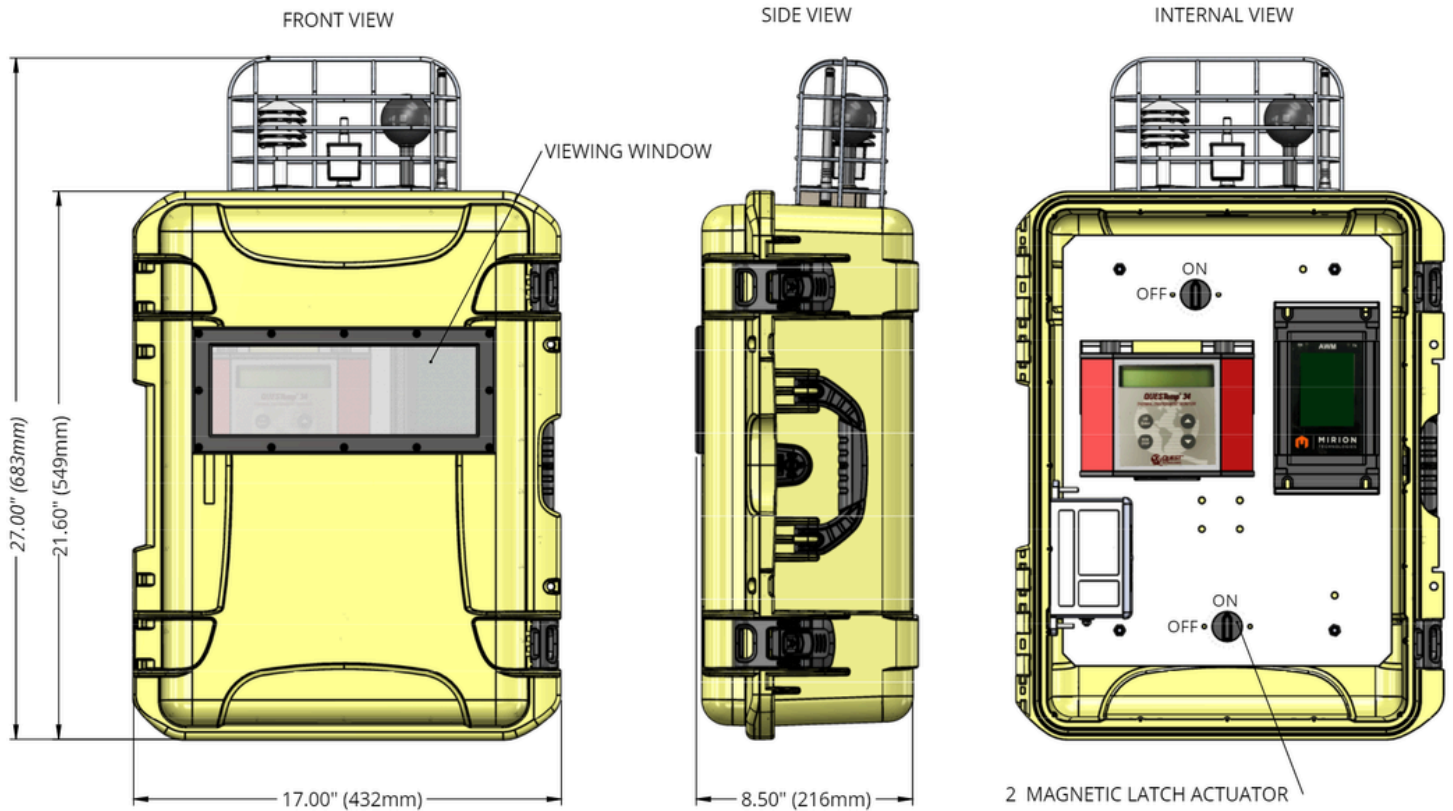

## Model number: 096154-940SC

- Designed to include client specified components and equipment such as power supplies, test equipment, sensors, and wireless transmission interfaces.
- The case can be mounted via 3 methods: on a vertical 1.6" Dia. stanchion, on a guard rail or by Dual Magnetic Quick Release Latch for mounting the case directly to a vertical steel surface such as a cabinet or an I-beam. (Mounting Plate supplied\*)
- Case includes a CSA and UL certified electrical interface - SED Inc.'s Power Distribution Box (PDB-C) with a modular connection cord for AC mains to a standard 115VAC receptacle outlet.

\*Kits may be customized as per your specific application

\*Additional mounting plates can be purchased to allow relocation

### SPECIFICATIONS:

Dimensions	27" x 17" x 8.5" (683.2mm x 428.8mm x 217mm)
Viewing Window Area	10.5" x 3.5" (266.7mm x 88.9mm)
Weight (approx.)	17.5kg / 38.6lb (Includes all items shown)
Kit is designed to house:	Customer Supplied Mirion Adaptive Wireless Monitor (AWM), Questemp 32 QT-32
Kit includes:	SED Inc's PDB-C, 6' Modular Connection cord, Interconnection Cable (15 sub-D) and, Antenna
	Steel mounting plate for Stanchion and Guard Rail mounting, Magnetic Clamps
Attachment Security:	For Guard Rail - Cable Ties
	For Stanchion - Bolt (Inserted into top tube receiver)

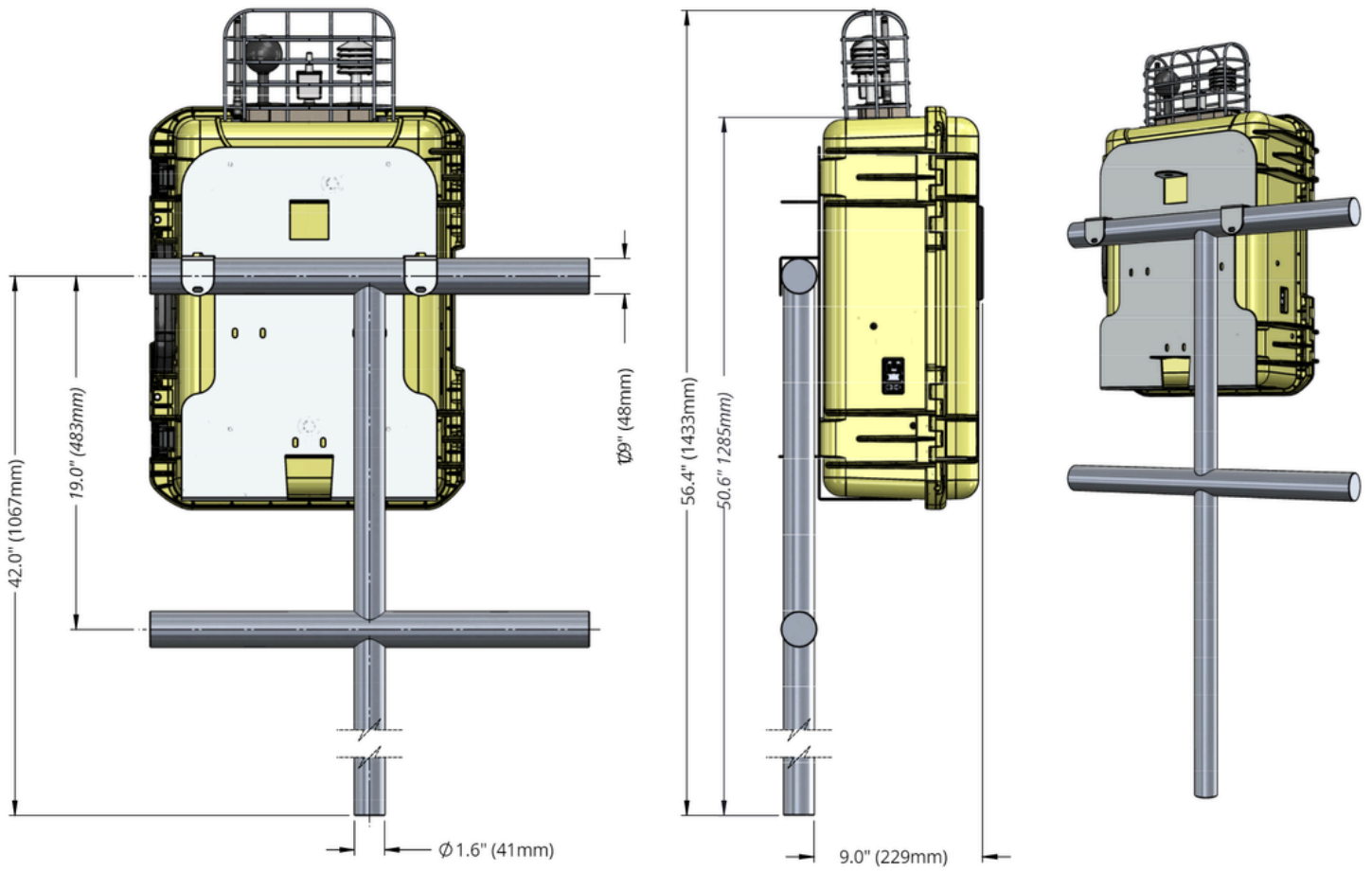

## MOUNTING STYLE 1 - GUARD RAIL

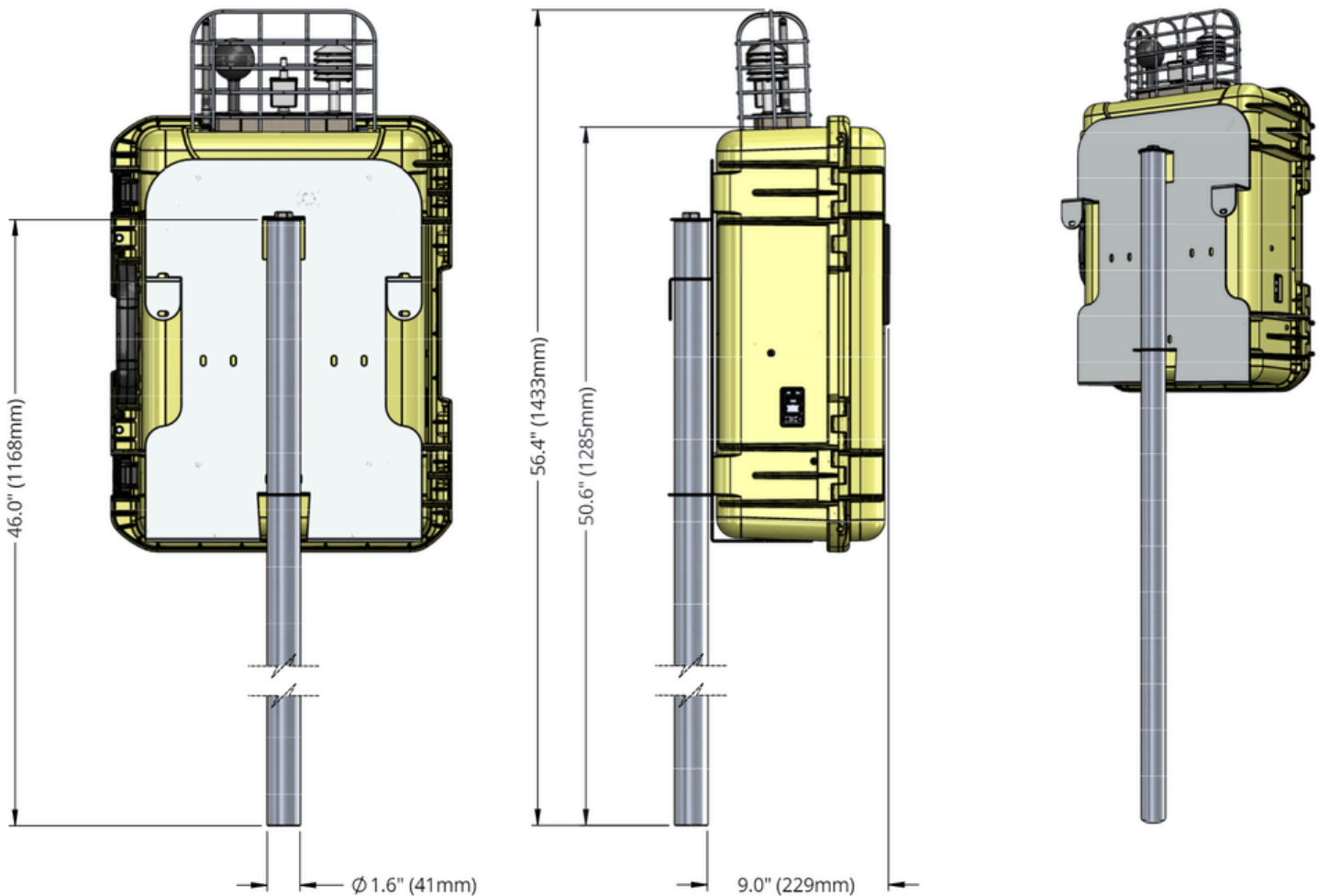

## MOUNTING STYLE 2 - STANCHION